

Diaphragm Valve, Plastic

Construction

All medium wetted parts, the bonnet and handwheel of the GEMÜ 677 2/2-way diaphragm valve are made of plastic. The maintenance-free plastic bonnet has an ergonomically designed handwheel with integral optical position indicator.

Features

- Suitable for inert and corrosive* liquid and gaseous media
- Valve body and diaphragm available in various materials and designs
- Insensitive to particulate media
- Optional flow direction and mounting position
- Versions according to ATEX on request

Advantages

- Body and diaphragm sizes have coordinated diameters, hence the fitting time is reduced because the pipe and fixing centres remain the same. Spares inventory is also reduced.
- Optional accessories
 - Electrical remote indication that the valve is in the open position
 - Lockable handwheel clamp
- Compact, weight-saving design
- Good specific flow capability
- Body with integrated mounting facility

*see information on working medium on page 2

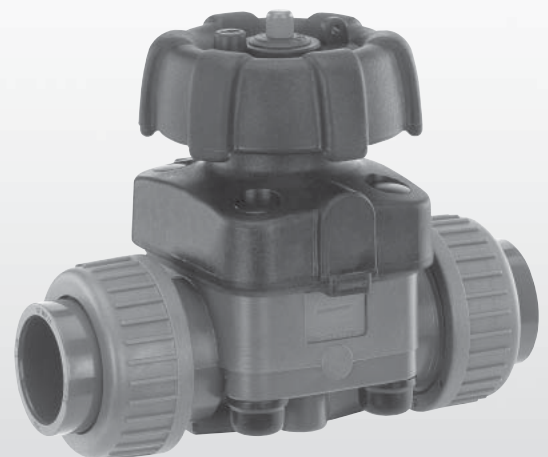

Sectional drawing

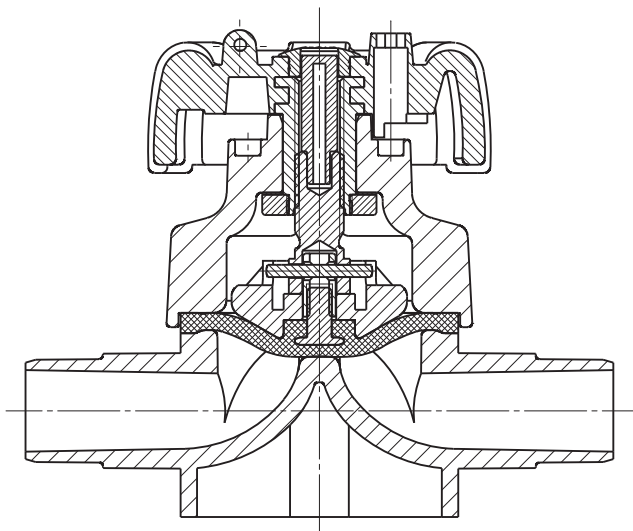

Technical data

Working medium

Corrosive, inert, gaseous and liquid media which have no negative impact on the physical and chemical properties of the body and diaphragm material.

Ambient temperature

Valve body PVC-U / PP / PP-H	5 to 60°C
Valve body ABS / PVDF	-10 to 60°C

Working medium temperature

Valve body PVC-U	5 to 60°C
Valve body ABS	-20 to 60°C
Valve body PP / PP-H	5 to 80°C
Valve body PVDF	-20 to 80°C

The permissible operating pressure depends on the working medium temperature.

O-ring material for valve bodies with union ends

Diaphragm material	O-ring material
CSM	EPDM
NBR	EPDM
FPM	FPM
EPDM	EPDM
PTFE	FPM

Other combinations on request

Pressure / temperature correlation for plastic

Temperature in °C (plastic body)		-20	-10	±0	5	10	20	25	30	40	50	60	70	80
Valve body material		Permissible operating pressure in bar												
PVC-U	Code 1	-	-	-	10.0	10.0	10.0	10.0	8.0	6.0	3.5	1.5	-	-
ABS	Code 4	10.0	10.0	10.0	10.0	10.0	10.0	10.0	8.0	6.0	4.0	2.0	-	-
PP	Code 5	-	-	-	10.0	10.0	10.0	10.0	8.5	7.0	5.5	4.0	2.7	1.5
PP-H	Code 71	-	-	-	10.0	10.0	10.0	10.0	8.5	7.0	5.5	4.0	2.7	1.5
PVDF	Code 20	10.0	10.0	10.0	10.0	10.0	10.0	10.0	9.0	8.0	7.1	6.3	5.4	4.7

Data for extended temperature ranges on request.

Please note that the ambient temperature and medium temperature generate a combined temperature at the valve body which must not exceed the above values.

Diaphragm size	DN	Operating pressure [bar]		Kv value [m³/h]
		EPDM / FPM	PTFE	
25	15	0 - 10	0 - 6	5.6
	20			8.2
	25			10.5
40	32	0 - 10	0 - 6	18.0
	40			25.0
50	50	0 - 10	0 - 6	46.0
80	65	0 - 10	0 - 6	78.0
	80			120.0
100	100	0 - 10	0 - 6	189.0

The above values are valid for both flow directions.

All pressures are gauge pressures. Operating pressure values were determined with static operating pressure applied on one side of a closed valve. Sealing at the valve seat and atmospheric sealing is ensured for the given values.

Information on operating pressures applied on both sides and for high purity media on request.

Kv values determined acc. to IEC 534 standard, inlet pressure 6 bar, Δp 1 bar, PVC-U valve body and soft elastomer diaphragm.

Order data

Body configuration	Code
2/2-way body	D

Connection	Code
Spigots DIN for socket welding	0
Flanges EN 1092 / PN10 / form B length EN 558, series 1 ISO 5752, basic series 1	4
Union ends with DIN insert (socket)	7
Spigots for IR butt welding	20
Spigots for IR butt welding, BCF	28
Spigots - inch	30
Union ends with inch insert (socket)	33
Flanges ANSI class 125/150 RF, length EN 558, series 1 ISO 5752, basic series 1	39
Union ends with DIN insert (for IR butt welding)	78

Valve body material	Code
PVC-U, grey	1
ABS	4
PP, reinforced	5
PVDF	20
Inliner PP-H grey / outliner PP reinforced	71

Diaphragm material	Code	
CSM	1	
NBR	2	
FPM	4	
EPDM	14	
PTFE/EPDM, PTFE loose	MG 25 - 50	5E*
PTFE/EPDM, PTFE laminated	MG 25 - 100	52
PTFE/FPM, PTFE loose	MG 25 - 50	5F*
PTFE/FPM, PTFE laminated	MG 25 - 100	56

* For use with valve bodies see page 8 MG = Diaphragm size

Control function	Code
Manually operated	0
Manually operated (lockable handwheel)	L

Options	Code
Threaded connection for position indicator	Z

Order example	677	15	D	0	1	14	0	Z
Type	677							
Nominal size		15						
Body configuration (code)			D					
Connection (code)				0				
Valve body material (code)					1			
Diaphragm material (code)						14		
Control function (code)							0	
Options (code)								Z

Actuator dimensions [mm]

Diaphragm size	DN	ø B	A	A4 ca.	X*	Weight [kg]
25	15 - 25	90	79	8	14	0.4
40	32 - 40	114	99	10	8	0.6
50	50	140	119	12	9	1.0
80	65 - 80	214	167	26	27	3.8
100	100	214	219	34	27	5.1

* X only with control function code L

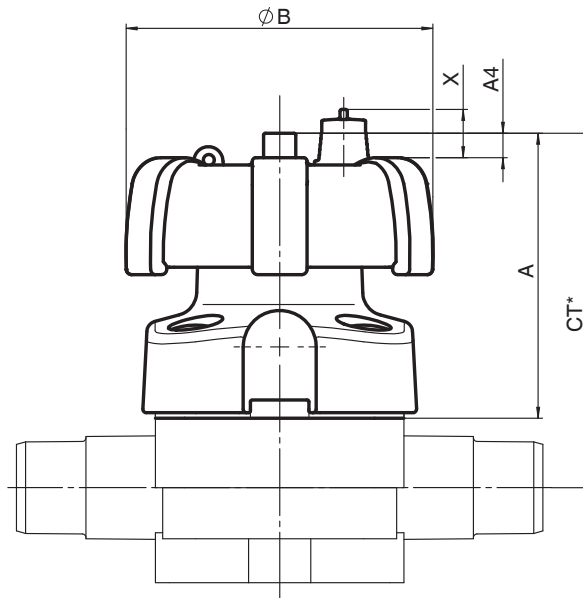

* CT = A + H1 (see body dimensions)

Mounting dimensions [mm]		
Diaphragm size	M	f
25	M6	25.0
40	M8	44.5
50	M8	44.5
80	M12	100.0
100	see drawing	

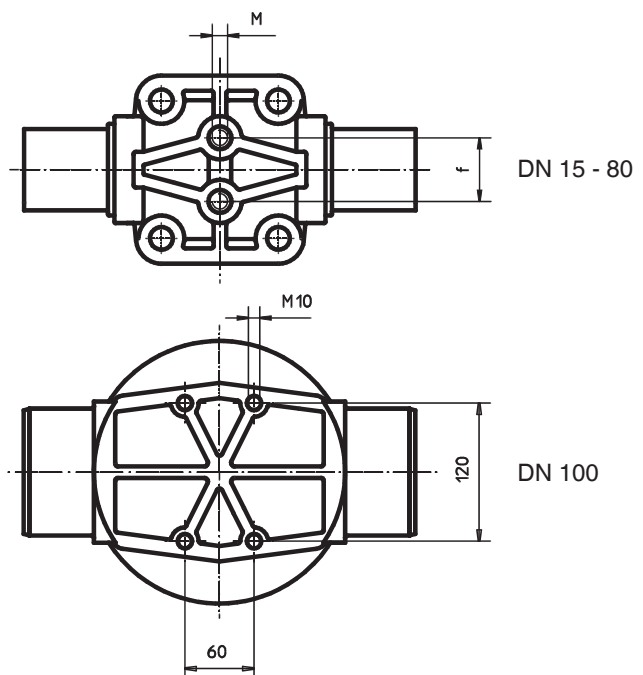

Body dimensions [mm]

Spigots - DIN, connection code 0

Valve body material: PVC-U (code 1), PP (code 5), PVDF (code 20), inliner PP-H (code 71)

MG	DN	NPS	L	H			H1			ød	c			Weight [kg]
				Material code 1	Material code 5	Material code 20, 71	Material code 1	Material code 5	Material code 20, 71		Material code 1	Material code 5	Material code 20, 71	
25	15	1/2"	124	45	-	50	19	-	24	20	16	-	18	0.24
	20	3/4"	144	45	-	50	19	-	24	25	19	-	19	0.24
	25	1"	154	45	-	50	19	-	24	32	22	-	22	0.34
40	32	1 1/4"	174	74	-	74	34	-	34	40	26	-	24	0.65
	40	1 1/2"	194	74	-	74	34	-	34	50	31	-	26	0.70
50	50	2"	224	78	-	82	38	-	42	63	39	-	29	1.10
80	65	2 1/2"	284	117	117	117	62	62	62	75	44	44	44	2.50
	80	3"	300	117	117	117	62	62	62	90	51	51	51	4.00
100	100	4"	340	140	140	140	75	75	75	110	61	61	61	4.40

For materials see overview on last page

MG = diaphragm size

Spigots - inch, connection code 30

Valve body material: PVC-U (code 1), ABS (code 4)

MG	DN	NPS	L	H	H1	ød	c	Weight [kg]
25	15	1/2"	141	45	19	21.4	24	0.24
	20	3/4"	145	45	19	26.7	27	0.24
	25	1"	154	45	19	33.6	30	0.34
40	32	1 1/4"	174	74	34	42.2	33	0.65
	40	1 1/2"	194	74	34	48.3	39	0.70
50	50	2"	224	75	35	60.3	40	1.10
80	65	2 1/2"	284	117	62	73.1	44	2.50
	80	3"	300	117	62	88.9	51	4.00
100	100	4"	340	140	75	114.3	61	4.40

For materials see overview on last page

MG = diaphragm size

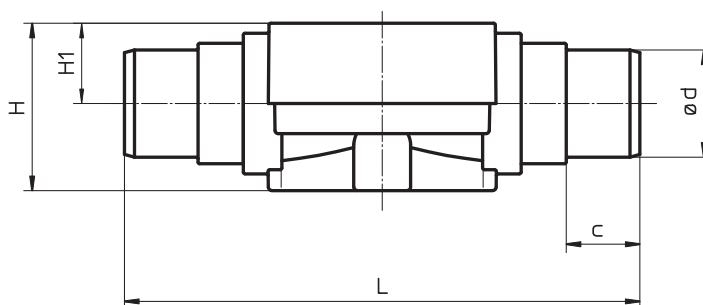

Body dimensions [mm]

Union ends with insert, connection code 7, 33 Valve body material: PVC-U (code 1), PVDF (code 20), inliner PP-H (code 71)

								Connection code 7			Connection code 33		Weight [kg]	
MG	DN	NPS	R	øD	L1	H	H1	L2			ød	L2		ød
								Material code 1	Material code 20	Material code 71				
25	15	1/2"	G 1	43	108	50	24	146	146	143	20	146	21.4	0.32
	20	3/4"	G 1 1/4	53	108	50	24	152	150	146	25	152	26.7	0.38
	25	1"	G 1 1/2	60	116	50	24	166	162	158	32	166	33.6	0.42
40	32	1 1/4"	G 2	74	134	74	34	192	184	181	40	192	42.2	0.88
	40	1 1/2"	G 2 1/4	83	154	74	34	222	210	207	50	222	48.3	0.97
50	50	2"	G 2 3/4	103	182	82	42	264	246	243	63	264	60.3	1.60

For materials see overview on last page

MG = diaphragm size

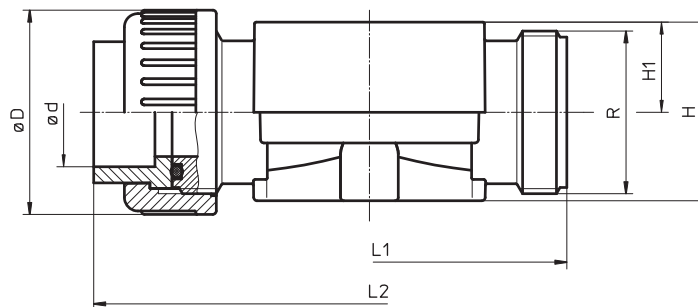

Spigots for IR butt welding, connection code 20 Valve body material: PVDF (code 20), inliner PP-H (code 71)

MG	DN	L	H	H1	ød	s		c	Weight [kg]
						Material code 20	Material code 71		
25	15	154	50	24	20	-	1.9	33	0.18
	20	154	50	24	25	-	2.3	33	0.18
	25	154	50	24	32	-	2.9	33	0.18
40	32	194	74	34	40	-	3.7	33	0.43
	40	194	74	34	50	-	4.6	33	0.64
50	50	224	82	42	63	-	5.8	33	0.69
80	65	284	117	62	75	3.6	-	43	3.57
	80	300	117	62	90	4.3	-	51	3.30
100	100	340	140	75	110	5.3	-	59	4.00

For materials see overview on last page

MG = diaphragm size

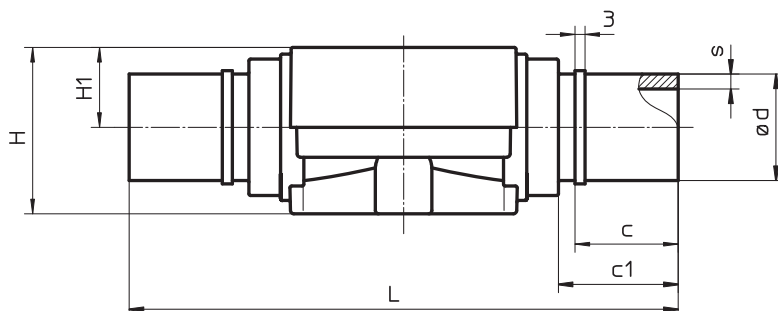

Body dimensions [mm]

**Spigots for IR butt welding, BCF, connection code 28
Valve body material: PVDF (code 20)**

MG	DN	L	H	H1	ød	c	c1	s	Weight [kg]
25	15	154	50	24	20	31	37	1.9	0.24
	20	154	50	24	25	31	37	1.9	0.25
	25	154	50	24	32	31	37	2.4	0.26
40	32	194	74	34	40	40	46	2.4	0.65
	40	194	74	34	50	40	46	3.0	0.66
50	50	224	82	42	63	40	46	3.0	1.10

MG = diaphragm size

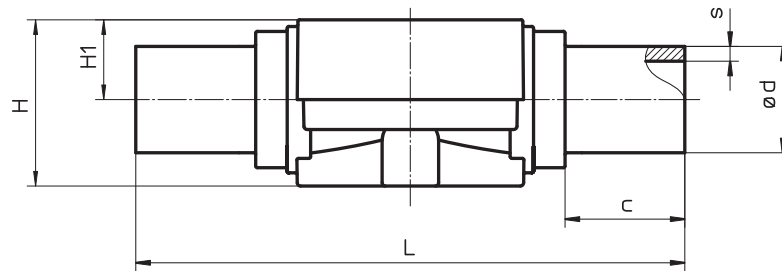

**Union ends with insert, connection code 78
Valve body material: PVDF (code 20), inliner PP-H (code 71)**

MG	DN	L1	L2	H	H1	øD	ød	R	s		c	Weight [kg]
									Material code 20	Material code 71		
25	15	108	214	50	24	43	20	G 1	1.9	1.9	36	0.34
	20	108	220	50	24	53	25	G 1 1/4	1.9	2.3	37	0.39
	25	116	234	50	24	60	32	G 1 1/2	2.4	2.9	39	0.45
40	32	134	258	74	34	74	40	G 2	2.4	3.7	39	0.88
	40	154	284	74	34	83	50	G 2 1/4	3.0	4.6	43	1.10
50	50	182	318	82	42	103	63	G 2 3/4	3.0	5.8	43	1.70

For materials see overview on last page

MG = diaphragm size

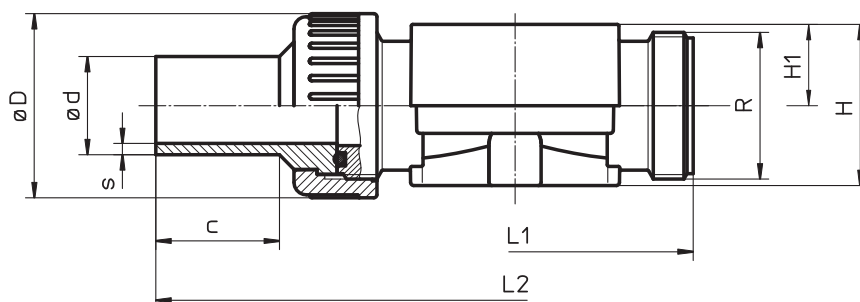

Body dimensions [mm]

Flanges, connection code 4, 39 Valve body material: PP (Code 5), PVDF (code 20), inliner PP-H (code 71)

MG	DN	FTF	H	H1	Connection code 4					Connection code 39					Weight [kg]		
					øD	øL	ød		øk	Number of bolts	øD	øL	ød			øk	Number of bolts
Material code							5, 71	20					5, 71	20			
25	15	150*	depending on material code see body dimensions page 5 connection code 0	depending on material code see body dimensions page 5 connection code 0	95	14	45	45	65	4	95	16	45	45	60	4	0.73
	20	150			105	14	58	58	75	4	105	16	54	54	70	4	0.89
	25	160			115	14	68	68	85	4	115	16	63	63	79	4	1.30
40	32	180			140	18	78	78	100	4	140	16	73	73	89	4	2.10
	40	200			150	18	88	88	110	4	150	16	82	82	98	4	2.50
50	50	230			165	18	102	102	125	4	165	19	102	102	121	4	3.20
80	65	290			185	18	122	120	145	4	185	19	122	120	140	4	4.60
	80	310			200	18	138	125	160	8	200	19	133	125	152	4	6.70
100	100	350			220	18	158	150	180	8	229	19	158	150	190	8	8.20

For materials see overview below

MG = diaphragm size

* Length is not according to EN 558 series 1

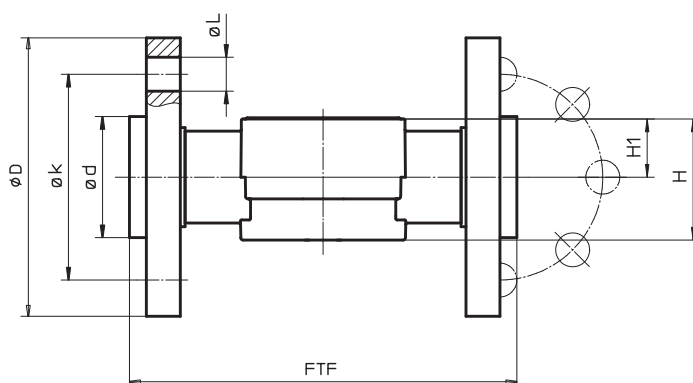

Overview of valve bodies for GEMÜ 677

Connection code		0				4			7			20		28	30		33	39			78		
Material code		1	5	20	71	5	20	71	1	20	71	20	71	20	1	4	1	5	20	71	20	71	
MG	DN																						
25	15	X	-	X	X	-	X	X	X	X	X	-	X	X	X	X	X	-	X	X	X	X	
	20	X	-	X	X	-	X	X	X	X	X	-	X	X	X	X	X	-	X	X	X	X	
	25	X	-	X	X	-	X	X	X	X	X	-	X	X	X	X	X	-	X	X	X	X	
40	32	X	-	X	X	-	X	X	X	X	X	-	X	X	X	X	X	-	X	X	X	X	
	40	X	-	X	X	-	X	X	X	X	X	-	X	X	X	X	X	-	X	X	X	X	
50	50	X	-	X	X	-	X	X	X	X	X	-	X	X	X*	X*	X	-	X	X	X	X	
80	65	X*	X*	X*	-	X*	X*	-	-	-	-	X*	-	-	X*	X*	-	X*	X*	-	-	-	
	80	X*	X*	X*	-	X*	X*	-	-	-	-	X*	-	-	X*	X*	-	X*	X*	-	-	-	
100	100	X*	X*	X*	-	X*	X*	-	-	-	-	X*	-	-	X*	X*	-	X*	X*	-	-	-	

* Valve bodies are not suitable for use with diaphragms code 5E and 5F

MG = diaphragm size

For further plastic diaphragm valves, accessories and other products, please see our Product Range catalogue and Price List. Contact GEMÜ.

GEMÜ® VALVES, MEASUREMENT AND CONTROL SYSTEMS

