

# Operating Manual

---



TREION™ OmniaPure xs<sup>touch</sup> Blueline





# Foreword

Dear Ladies and Gentlemen,

The stakpure GmbH team thanks you for the trust you have placed in us.

By choosing this ultrapure water system from our company, you have opted for an innovative, high-quality and durable product.

Before installing and starting up your ultrapure water system, please read the installation and operating instructions in this operating manual carefully.

Note that only trained personnel are allowed to operate this system.

To ensure water quality, only use original accessories, spare parts and consumables from stakpure.

Please note that we as the manufacturer cannot assume any liability for any damage to the system connected peripherals or buildings and persons in the event of improper use or improper assembly or operation, or the use of third-party parts of any kind.

We wish you success with your new water treatment system

stakpure GmbH, September 2022.

# Table of Contents

1	User Notes .....	7
2	Safety instructions .....	8
3	Intended Use .....	10
4	Transport and packaging .....	11
5	Delivery package .....	12
6	Technical data .....	12
7	Flow charts .....	15
7.1	Flow chart OmniaPure xs <sup>touch</sup> UV-TOC .....	15
7.2	Flow chart OmniaPure xs <sup>touch</sup> UV-TOC/UF .....	15
8	System description .....	16
8.1	System connections on the back .....	17
9	Function description .....	17
10	Assembly .....	18
10.1	Operating environment .....	18
10.2	Assembly .....	18
10.3	Wall mounting .....	21
11	Operating concept .....	23
11.1	Main display .....	23
11.2	Navigation .....	24
11.3	Operating concept .....	25
11.4	Volume metered water to be withdrawn .....	26
11.5	Client menu .....	27
11.6	Setup menu .....	28
11.7	Calibrating menu .....	29
12	Commissioning .....	30
13	Maintenance .....	31
13.1	Maintenance / Care intervals .....	31
13.2	Changing the cartridges .....	32
13.3	Disinfection .....	33
14	Decommissioning & Dismantling .....	34
15	Spare parts .....	35
16	Consumables .....	35
17	Accessories .....	35

18	Faults / Messages .....	36
18.1	Faults table .....	36
18.2	Error messages .....	37
19	Disposal .....	39
20	EU declaration of conformity .....	40

## Symbols used



Warning notices with this symbol indicate a hazard which, if not avoided, could result in death or serious injury.



Warning notices with this symbol indicate a hazard which, if not avoided, could result in minor or moderate injury.



This symbol indicates a risk with possible property damage.



This symbol indicates useful information.

## 1 User Notes

Read this manual completely and carefully before installing and operating the OmniaPure xs system for the first time. It is an important part of the product and contains basic information that must be observed during installation, operation and maintenance.



The operating instructions must be available at the place of operation at all times. If you let other people use the OmniaPure xs system, pass on also these Operating Manual.

The personnel for operation, maintenance, inspection and assembly must have the appropriate qualifications for this type of work. The area of responsibility, competence and supervision of the staff must be precisely regulated by the operator.

Not only the safety instructions listed in this section must be observed, but also the safety regulations applicable to the installation site. In particular, the accident prevention regulations.

## 2 Safety instructions

The safety instructions described below are for your own safety and help to prevent possible damage to the OmniaPure xs system. Read the instructions before installation, commissioning and maintenance and follow them carefully.

 <p><b>WARNING</b></p>	<p><b>Danger of electric shock!</b>  <b>Improper electrical supply of the OmniaPure xs system can lead to an electric shock!</b></p> <ul style="list-style-type: none"> <li>- For the electrical supply of the OmniaPure xs system, only use the wide-range power pack included in the scope of delivery.</li> <li>- For the electrical supply of the wide-range power pack of the OmniaPure xs system, only use a properly grounded socket that provides an AC voltage of 100-240V with 50-60Hz. The power supply must be attached to the device or the wall.</li> <li>- For maintenance work, the rear housing cover may only be opened when the mains plug is unplugged.</li> </ul>
 <p><b>WARNING</b></p>	<p><b>Danger from falling!</b>  <b>Improper handling or attachment can cause the OmniaPure xs system to fall and cause injury!</b></p> <ul style="list-style-type: none"> <li>- Always ensure that the system is in a secure position.</li> <li>- When mounting on a wall, ensure that the system is mounted in a correspondingly stable manner.</li> <li>- When handling / transporting the system, observe the system's attachment points, which you can find in this operating manual.</li> </ul>
 <p><b>WARNING</b></p>	<p><b>Danger from slipping!</b>  <b>Incorrect or faulty installation or operation as well as a leak in the system can lead to the uncontrolled escape of liquid and thus to a risk of slipping!</b></p> <ul style="list-style-type: none"> <li>- Always ensure that the system is operated correctly and always use a sufficiently large container when withdrawing water.</li> <li>- Make sure the inlet and outlet lines are tight.</li> <li>- Make sure that the rinsing water is drained into a drain without pressure.</li> </ul>





### **Danger of skin and eye injuries!**

#### **Contact with the disinfectant can lead to skin and eye irritation and/or injuries!**

- Always wear appropriate protective clothing (at least gloves & goggles) when disinfecting the OmniaPure xs system to avoid contact with the disinfectant.
- Make sure that no disinfectant can escape uncontrolled from the OmniaPure system, check the connection hoses for correct and tight fit.
- Follow the instructions that come with the disinfectant agent or disinfection kit.

#### **Escaping UV radiation can cause skin and eye irritation or injuries!**

- Only change the UV lamp of an OmniaPure xs system when it is switched off and the mains plug is unplugged.
- When changing the UV lamp, make sure that the lamp is correctly seated in the UV reactor.



### **Danger of crushing and pinching injuries!**

#### **Incorrect handling of the OmniaPure xs system can lead to crushing and pinching injuries!**

- When handling / transporting the system, observe the system's attachment points, which you can find in this operating manual.
- When handling the movable dispenser arm, pay attention to possible pinch points in the area of the joint on the main housing. Move the arm only by holding the dispenser handle.

The safety instructions contained in these operating instructions, the existing national accident prevention regulations and any internal work, operating and safety regulations of the operator must be observed.

These operating instructions must be available at the place of operation at all times.

Installation, operation and maintenance of the system may only be carried out by trained specialist personnel.

The CE mark loses its validity in the event of structural changes or the installation of accessories not authorised by the manufacturer. Conversion and modification of the system are only permitted after consultation with the manufacturer. Original spare parts and accessories authorised by the manufacturer ensure safety.

Please note that the manufacturer is exempt from any liability for damage caused by improper use or use that is not in accordance with the intended purpose.



Protect the system from frost. The ambient temperature at the installation site should be at least +2°C.

Only operate the system within the range of the specified feed water pressure.

Access to the mains cable and the mains plug must always be freely accessible.

A safety device to protect against contamination of the drinking water according to DIN EN 1717 must be used for the connection of water treatment systems.

Depending on the country, a safety combination consisting of a backflow preventer and a system separator may have to be available on the building side.

A DN 50 floor drain with free drainage is to be provided in the operating room. If there is no floor drain, we recommend using a water monitor to prevent damage to the system and equipment as well as the building. Otherwise, the manufacturer assumes no liability for any water damage that may occur.

The base of the system must have sufficient load-bearing capacity (for weight, see technical data).

When assembling, make sure that there is enough free space for problem-free operation, maintenance and repairs.

Maintenance work may only be carried out by trained specialists.

### 3 Intended Use

The systems of the OmniaPure xs series are used to treat water into ultrapure water. In order to ensure maximum quality of the ultrapure water with the longest possible service life of the consumables, the OmniaPure xs system must be fed with water from a pre-treatment stage. A reverse osmosis system, a still or an ion exchanger can be used in a pre-treatment phase.

The ultrapure water produced is used as a solvent or rinsing agent in a wide variety of analytical methods such as high-performance liquid chromatography (HPLC), ion chromatography (IC), atomic absorption spectrometry (AAS), ultratrace analysis, etc. It is also used in a variety of chemical and biochemical applications such as preparing reagents, cultivating cells, etc.

The treated ultrapure water is not suitable for consumption.

The system must not be used for the production of pharmaceuticals and is not a medical device.

## 4 Transport and packaging

The OmniaPure xs systems are carefully inspected and packaged prior to shipment, however damage may occur in transit.

Check the packaging and the system for possible transport damage. If you find any damage, please contact the shipping or transport company responsible for the delivery directly.



For transport, only lift the device at holding points 1, 2 and 3.

Never lift the device by the dispenser hose point 4 or the dispenser arm point 5, as this may damage the device.

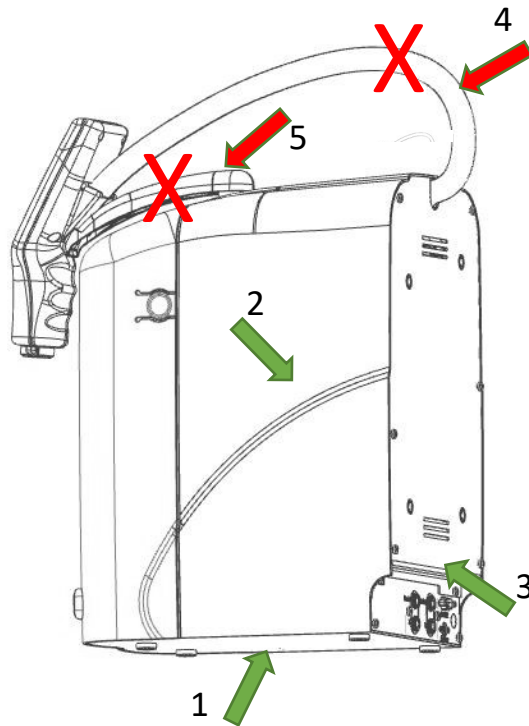

## 5 Delivery package

The scope of delivery of the OmniaPure xs system consists of the following parts:

Position	Number	Designation
01	1	OmniaPure xs <sup>touch</sup> Blueline System
02	1	Table power supply 48V 120W
03	1	Power cord
04	1	PE hose d8 2,5m
05	1	PE hose d8 incl. input protection filter and Water connection adapter R ¾" – d8
06	2	Insertion angle d8
07	1	Pretreatment cartridge
08	1	Ultrapure water cartridge
09	1	Sterile filter
10	1	Operating manual

## 6 Technical data

Feedwater requirements	
Source	Drinking water pretreated by deionization
Pressure [bar]	0,5 – 6 <sup>1</sup>
Temperature [°C]	2 – 35
Conductivity [µS/cm]	< 100
TOC [ppb]	< 50

1. At pressures below 0.5 bar the system will work, but the product water flow rate may be lower.

Product water ASTM I <sup>1</sup>		
	OmniaPure xs <sup>touch</sup>	
	UV-TOC	UV-TOC/UF
Conductivity [µS/cm] at 25°C	0.055	0.055
Resistance [MΩ cm] at 25°C	18.2	18.2
TOC [ppb]	< 2	< 5
Particle > 0,2 µm [1/ml] <sup>2</sup>	< 1	< 1
Bacteria [KBE/ml] <sup>2</sup>	< 0.01	< 0.01
Pyrogen (Endotoxin) [EU/ml] <sup>3</sup>	-	< 0.001
Ribonuclease [pg/ml] <sup>3</sup>	-	< 1
Deoxyribonuclease [pg/ml] <sup>3</sup>	-	< 5
Proteases [µg/ml] <sup>3</sup>	-	< 0.15
Flow [l/min]	Up to 2	Up to 2

1. The values given are typical and may vary depending on the quality of the feed water.

2. With sterile filter capsule 19100300 or bio final filter 19102100.

3. With bio final filter 19102100.

Water connections	
Feed water inlet	Hose AD 8mm
Rinse water outlet	Hose AD 8mm
Threaded connection for sterile filter	G1/4"
Sterile filter outlet	Hose tail 6mm

Electrical connection	
Voltage	100 – 240 VAC
Frequency	50/60Hz
Power consumption (max.)	120W
USB interface	USB socket type A
Serial interface (optional)	RS 232

Cell Constants	
Conductivity measuring cell LF 1	0.01 cm <sup>-1</sup>
Conductivity measuring cell LF 2	0.01 cm <sup>-1</sup>
Conductivity measuring cell LF 3	0.01 cm <sup>-1</sup>

Airborne noise emission	
Sound pressure level	50 dB(A)

Environmental conditions	
Operating area	Inside
Max. height above sea level	Up to 2000 m
Ambient temperature	min. +2°C to max. 40°C, 80% rel. LF, non-condensing
Mains voltage fluctuation	Max ±10% of nominal voltage
Degree of pollution	2

Dimensions and Weights		
	OmniaPure xs <sup>touch</sup>	
	UV-TOC	UV-TOC/UF
Height in mm, aprox.	530	
Wide in mm, aprox.	240	
Depth in mm, aprox.	435	
Empty weight in kg approx.	14	
Operating weight kg approx.	15	

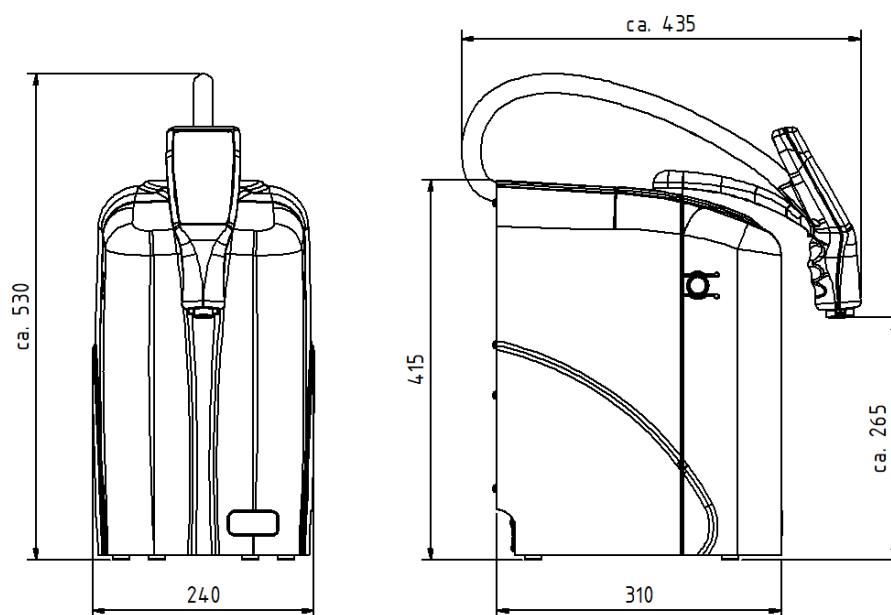

Materials of the components in contact with water	
Solenoid valve input	POM, EPDM
Flush solenoid valve	POM, EPDM
Withdrawal solenoid valve	POM, EPDM
Pressure reducer	POM
Pump head	Nylon, glass fiber reinforced
Conductivity cell	POM, stainless steel
Hoses	PE
Hose connection	POM
Seals	EPDM
UV reactor	Stainless steel
UV immersion tube	Quartz glass
Ultra filter housing	PC

# 7 Flow charts

## 7.1 Flow chart OmniaPure xs<sup>touch</sup> UV-TOC

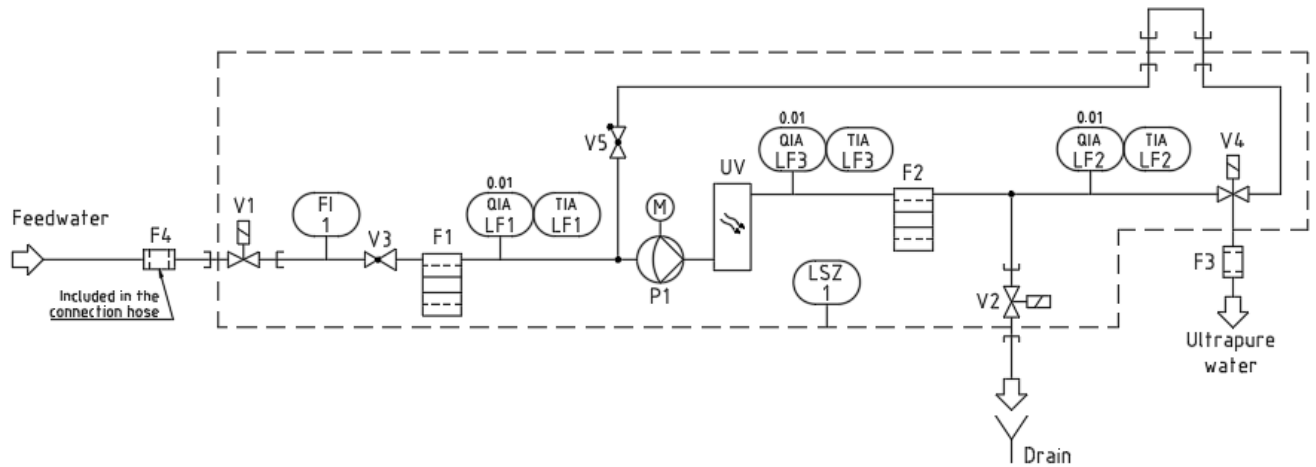

## 7.2 Flow chart OmniaPure xs<sup>touch</sup> UV-TOC/UF

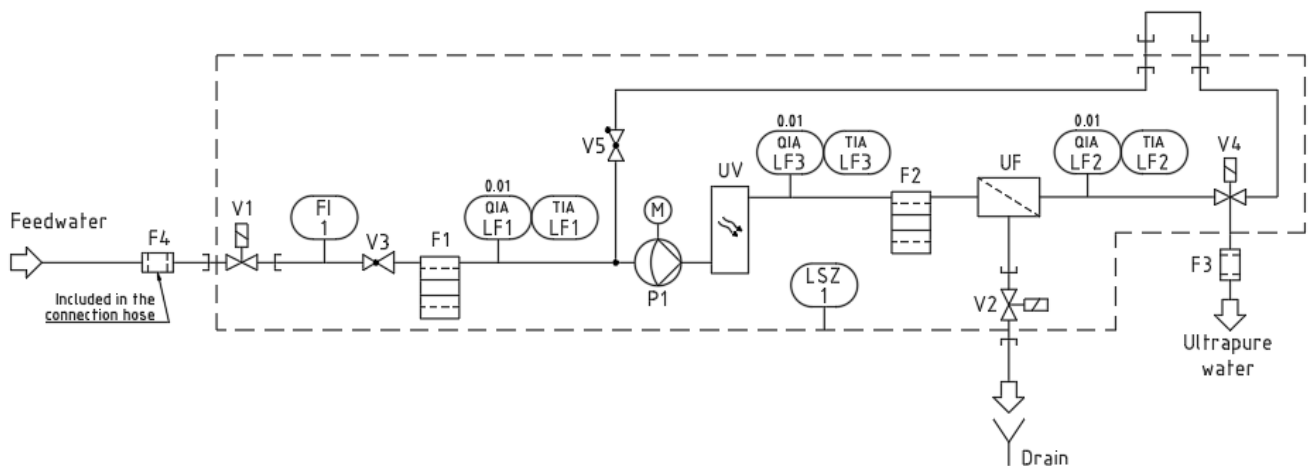

R+I no.	Designation	R+I no.	Designation
F1	Pretreatment cartridge	LF3	TIA Temperature sensor TOC
F2	Ultrapure water cartridge	LSZ1	Leakage sensor
F3	Sterile filter	P1	Circulation pump
F4	Hat filter (in the connection hose)	UF	Ultrafiltration module
FI1	Flow meter	UV	UV Photooxidation
LF1	QIA Conductivity cell pretreatment	V1	Inlet solenoid valve (in block)
LF1	TIA Temperature sensor pretreatment	V2	Rinsing solenoid valve (in block)
LF2	QIA Conductivity cell ultrapure water	V3	Pressure reducer
LF2	TIA Temperature sensor ultrapure water	V4	Withdrawal solenoid valve
LF3	QIA Conductivity cell TOC	V5	Check valve

## 8 System description

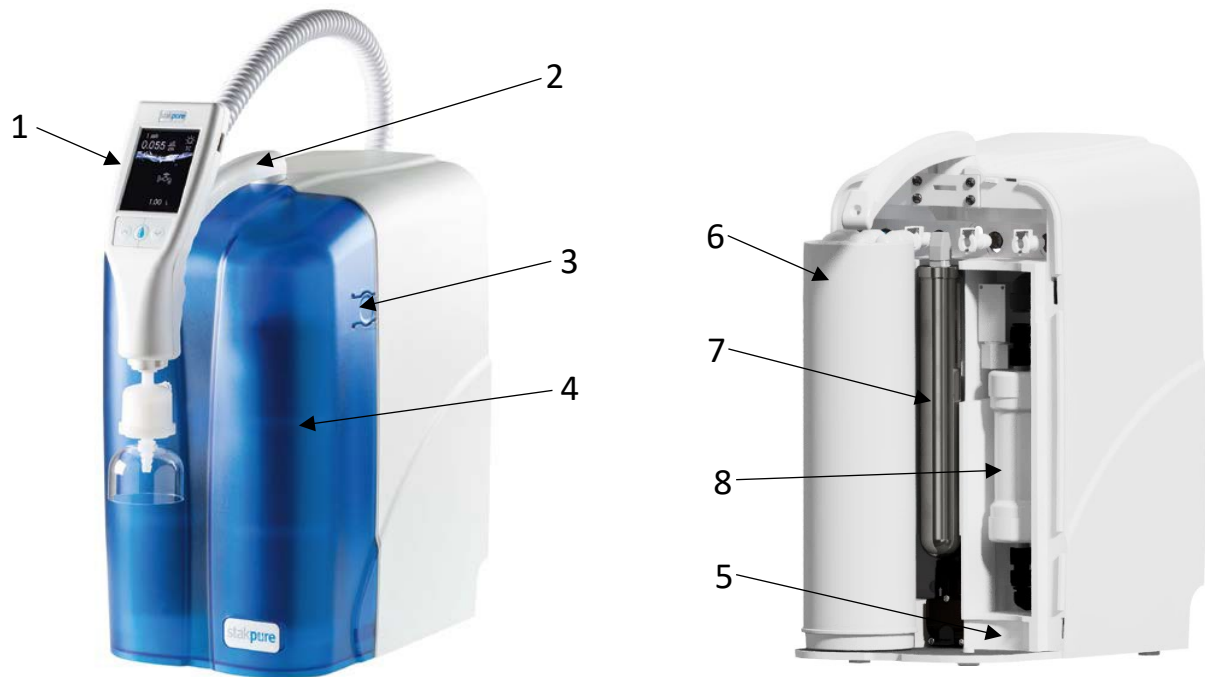

- |   |   |
|---|---|
| <p>1: Detachable OptiFill dispenser with integrated control unit and USB port</p> <p>2: Rotating dispenser arm</p> <p>3: Snap closure</p> <p>4: Removable cover hood</p> <p>5: Space for pre-treatment cartridge (not in the picture)</p> | <p>6: Ultrapure water cartridge</p> <p>7: UV reactor</p> <p>8: Ultrafiltration module</p> <p>9: Dispenser admission</p> <p>10: USB port</p> |
|---|---|

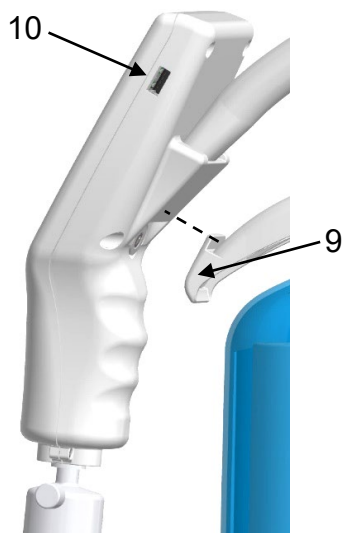



## 8.1 System connections on the back



<p>Inlet: Feed water connection          Drain: Rinse water connection          1: Connection accessories flow          2: Connection accessories return</p>	<p>Power: Power supply connection          RS232: Connection for data printer          (Option)</p>
--	---

## 9 Function description

The systems of the OmniaPure xs series prepare pre-treated water into ultrapure water by using several treatment technologies. This ultrapure water meets the respective requirements of the ASTM, ISO, USP and CLSI standards.

For treatment, the water (feed water) that has already been pretreated by reverse osmosis, distillation or deionization is fed into the OmniaPure xs system. The feed water first flows through the pre-treatment cartridge, which already removes a large part of the ions and organic compounds. The quality of the appropriately pre-treated water and thus also the condition of the pre-treatment cartridge are continuously monitored by the first conductivity measurement (LF1). The current values of the conductivity measurement can be shown on the display of the operating/withdrawal unit (OptiFill Dispenser) for checking purposes.

In the next step, the water is pumped into the UV reactor, where UV radiation is used to photooxidize organic substances. The water then flows through the ultrapure water cartridge, which removes the remaining ions. Finally, to remove a maximum of non-ionized compounds, the water is filtered through an ultrafiltration module (only at OmniaPure xs UV-TOC/UF).

Before the water is dispensed through the OptiFill dispenser, the quality of the ultrapure water and the condition of the consumables are monitored using a temperature-compensated conductivity measurement (LF2). The conductivity values measured and the temperature are shown on the display of the OptiFill dispenser.

As a final treatment stage, the ultrapure water runs through a sterile filter immediately before it is withdrawn. In order to permanently ensure high ultrapure water quality, the ultrapure water periodically circulates through the ion exchange cartridge (F2), the UV reactor and the ultrafiltration module (only with OmniaPure xs UV-TOC/UF).

# 10 Assembly

## 10.1 Operating environment

When selecting the installation location, observe the following requirements:

- The pressure of the feed water must be between 0.5 and 6 bar.
- The standing surface must be level.
- A suitable protective contact socket must be available for the electrical supply of the OmniaPure xs system (see technical data).
- There must be sufficient free workspace for problem-free operation, maintenance and repairs.
- There must be sufficient space to operate the system.
- An on-site, lockable feed water connection with R $\frac{3}{4}$ " external thread is required.



The system is only intended for operation within an industrial environment. In other environments, electromagnetic immunity cannot be guaranteed.



Temperatures below +2°C can damage the device due to frost!

The feed water pressure must be less than 6 bar, otherwise the system can be damaged! If necessary, use a pressure reducer.

Make sure a free drain is available to avoid water damage!



A free outlet, primarily a funnel siphon DN 50, is to be provided for the rinsing water of the OmniaPure xs system in the immediate vicinity of the location. The upper edge of the outlet must not exceed a height of 300 mm above the level of the appliance in order to ensure free outlet and thus flawless functionality of the drain. It must be ensured that the flushing water line is neither closed nor throttled.



A DN 50 floor drain with free drainage is to be provided in the operating room. If there is no floor drain, we recommend using a water monitor to prevent damage to the system and equipment as well as the building.

## 10.2 Assembly



Set up the OmniaPure xs system at the operating site and make sure that the system is standing securely. When transporting the system, never lift it by the dispenser arm, only by the rear wall, bottom or side walls of the main body.



**CAUTION**

Water can escape through leaks. Therefore, always make sure that the floor in the area of the work surface is dry to avoid accidents caused by slipping.

Use the connection accessories to connect the OmniaPure xs system to the feed water connection and to the free drain. Observe the requirements for the feed water (see technical data). Connect the connection hose with integrated hat filter with its R3/4" internal thread to the house feed water connection. Now plug the free end of the 8mm hose into the 8mm quick connector labelled "Inlet" on the back of the system (see System Connections). Then connect the second 8mm hose to the "Drain" device connection and guide the free end of the hose into a drain, through which the rinsing water can drain without pressure.



**WARNING**

In order to protect the power pack from moisture, it must not be operated lying on the table next to the device. Attach the power pack to the device using the bracket included in the scope of delivery (e.g. to the rear wall, see figure) or to a suitable wall near the device.

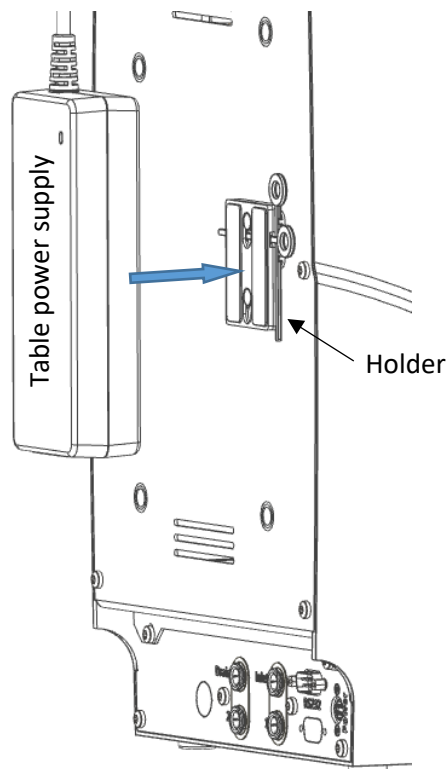

Plug the 4-pin connector of the power supply into the "Power" port of the OmniaPure xs system. Make sure that the mains connection cable is connected to the table power supply and then insert the safety plug into a suitable safety socket (see technical data).

Finally, open the shut-off valve on the building's feed water connection. Check the hose connections for leaks.

Remove the cover of the OmniaPure xs system and place the pretreatment cartridge in the right slot and the ultrapure water cartridge in the left slot. Connect the cartridges with the quick-release couplings by pushing them on. The quick-release fasteners must audibly click into place.

See the illustration:

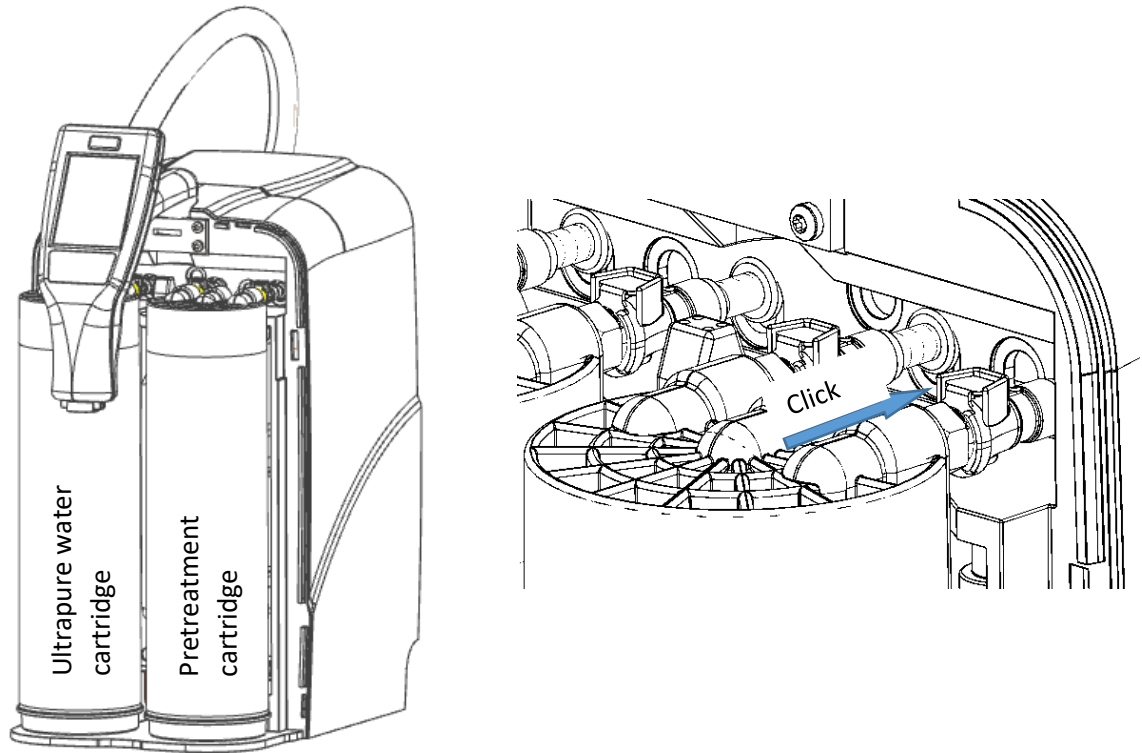

Screw the sterile filter with its R1/4" thread into the outlet of the OptiFill dispenser (see figure).

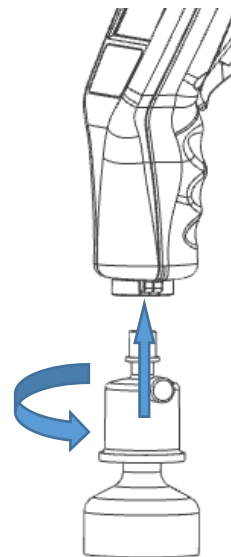

## 10.3 Wall mounting



### **Risk of injury from falling and crushing!**

The OmniaPure xs system may only be attached to a suitable wall using the optionally available wall holder. Use the wall mount exclusively for the OmniaPure xs system. Make sure that the wall and the fastening material have a sufficient load-bearing capacity of at least 100kg. The mounting hardware supplied with the wall mount is designed for use in conjunction with concrete or solid brick. Check the suitability of the fastening material in relation to the material of the wall and replace it with a suitable one if necessary.

With the optionally available wall holder, you can attach your OmniaPure xs system to a suitable wall to save space. The free wall area should be approx. (W x H) 300mm x 600mm. For professional and safe wall mounting, we recommend installation by our customer service.

First, your OmniaPure xs system must be prepared for wall mounting. The parts required for this are included in the scope of delivery of the wall bracket. Screw the four M8 standoffs into the M8 threaded bushings located on the back of the system. Then screw the two locating bolts into the spacer bolts at the top. The two stop buffers are screwed into the two lower spacer bolts on the back of the system (see illustration).

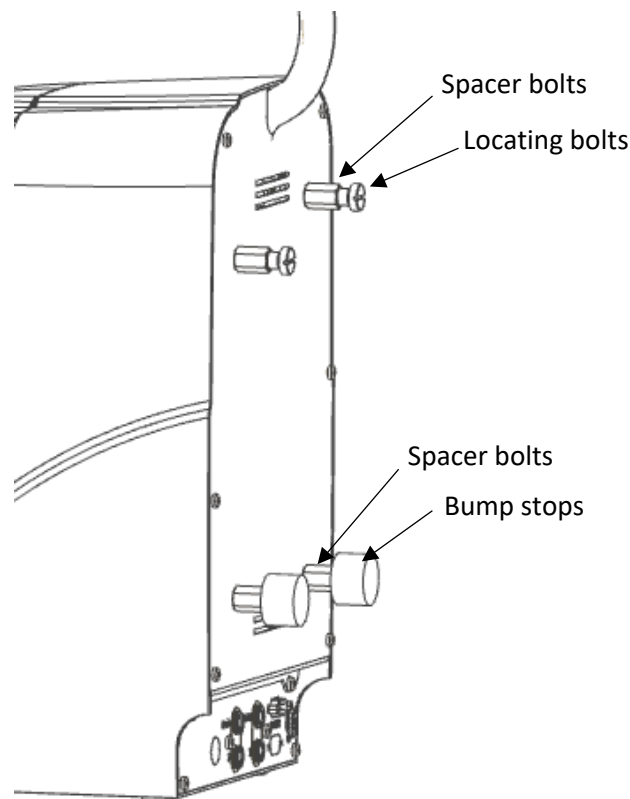

The next step is to attach the wall holder rail to the wall.

This requires 6 holes with a diameter of 8mm and a depth of at least 60mm. Drill the holes according to the pattern shown in the "Wall Mount Rail" figure below. Pay attention to a horizontal alignment.

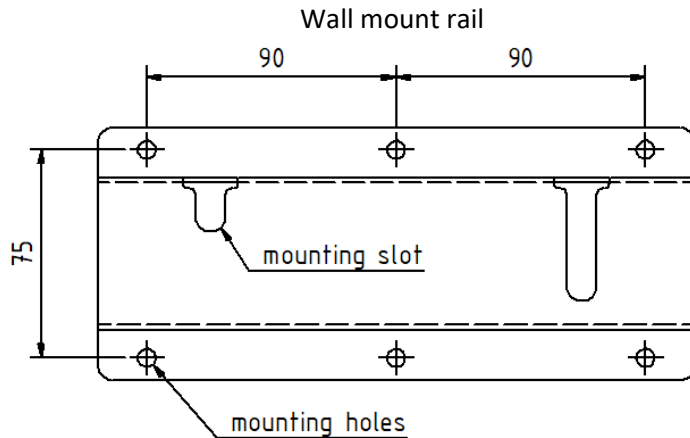

Then insert the dowels into the drilled holes and fasten the wall mounting rail to the wall with the screws so that the two mounting holes are facing upwards. Please note that the fastening material supplied with the wall holder is intended for installation in concrete and solid stone walls. If the wall holder is to be attached to a wall made of a different material, the fastening material must be replaced with a suitable one.

Now you can hang the OmniaPure xs system in the wall mounting rail. To do this, lift the system by grasping the specified holding points (see "Transport and packaging"). When lifting the system, secure yourself against falling with the help of a second person. Now hang the two locating bolts of the system in the locating openings of the wall mounting rail. Make sure that the system is additionally supported on the wall by the two stop buffers.

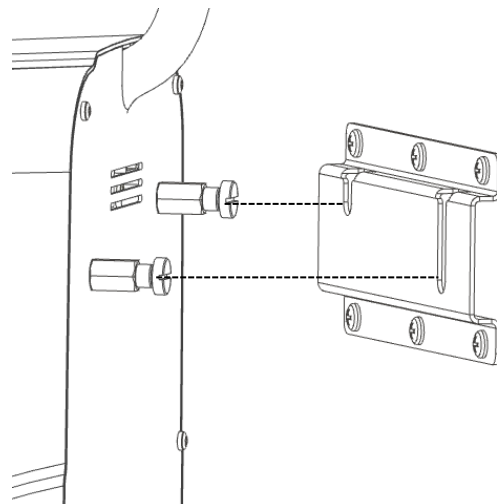

# 11 Operating concept

The Omnia devices are operated using the three buttons below the display. If entries are required in the respective menus, an ESC and Enter key also appear as touch keys on the screen.

You get to the menus by "swiping", if you push the main display up, you get to the customer menu. All other conductivities including limit value and temperature of the corresponding measuring cell, operating hours (pumps, UV) are displayed there.

If you slide the screen to the left, you first get to the setup menu. You then navigate through the setup menu in a vertical direction.

If you move the screen from the setup menu even further to the left, you get to the calibration menu. You then navigate through the calibration menu in a vertical direction.

## 11.1 Main display

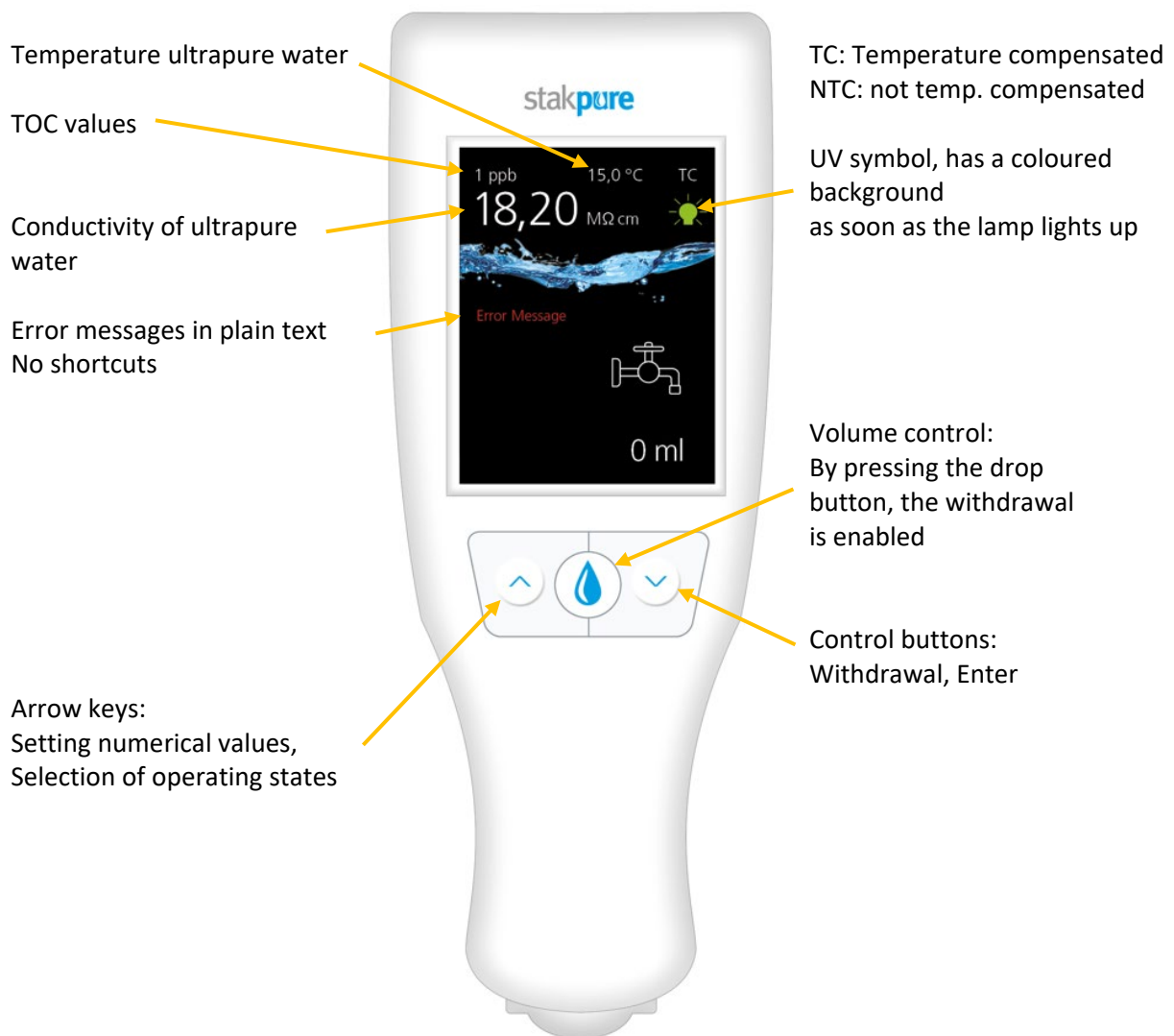

## 11.2 Navigation

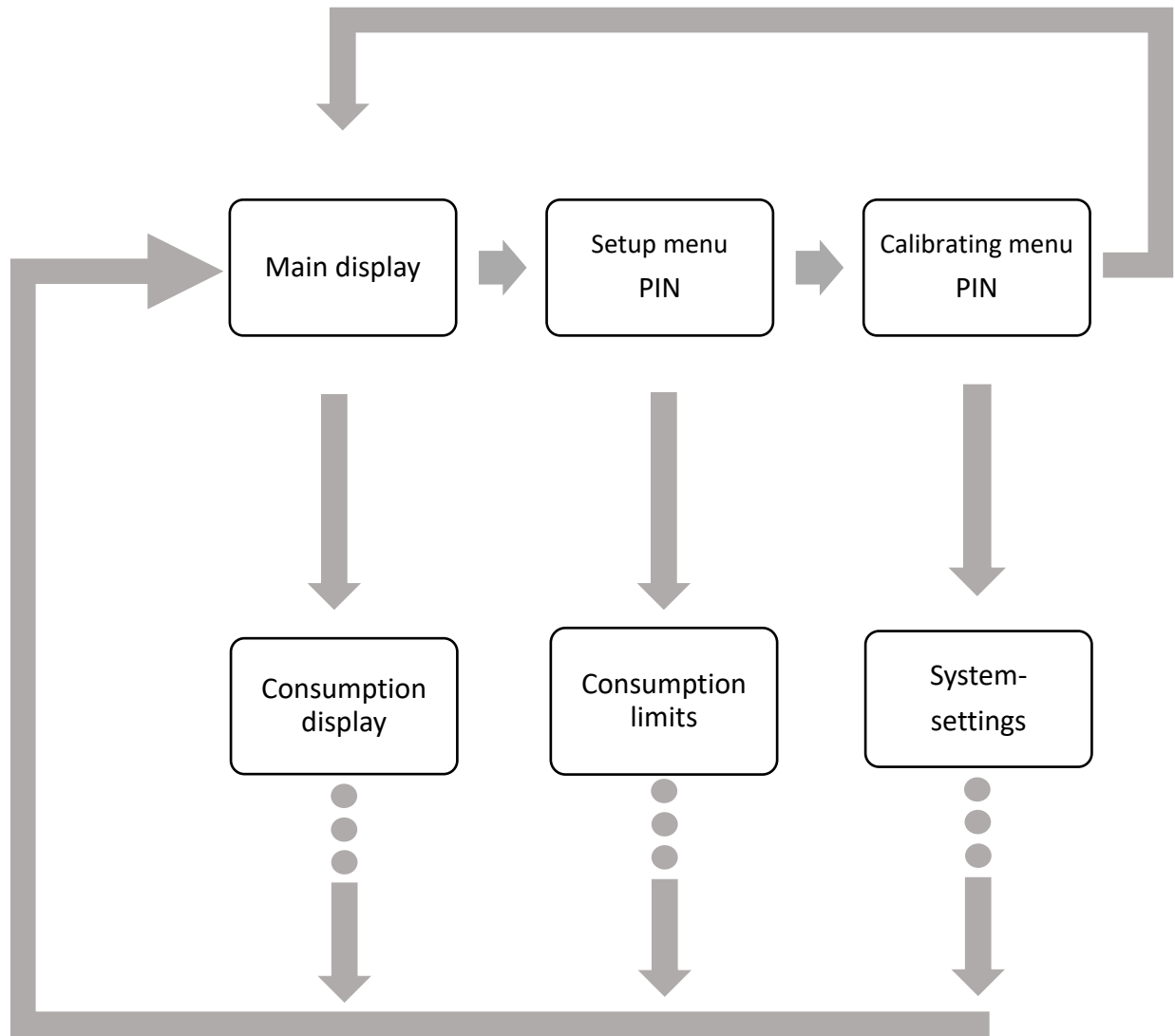



## 11.3 Operating concept

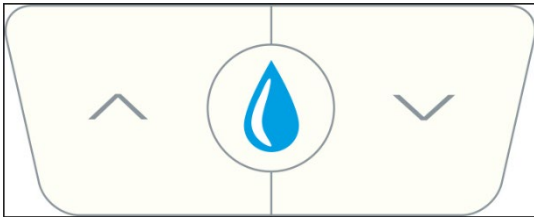

After pressing the "Change" soft key, the selected line is highlighted in red.

Another value can be selected by pressing the arrow key.

The input is activated with the drop key and the cursor jumps to the first digit.

Use the drop button to move the cursor to the position to be changed and use the arrow keys to set the desired value.

Then confirm the input with Enter and exit the menu with the Home button.

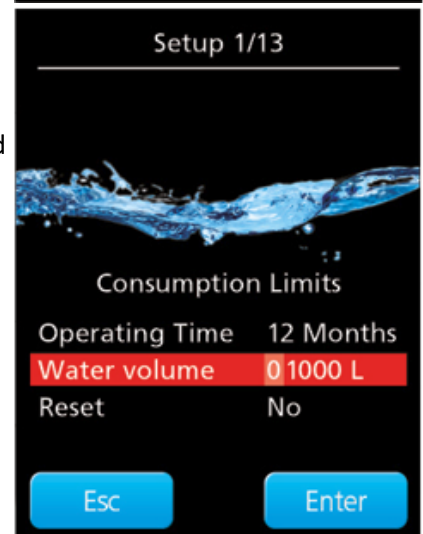
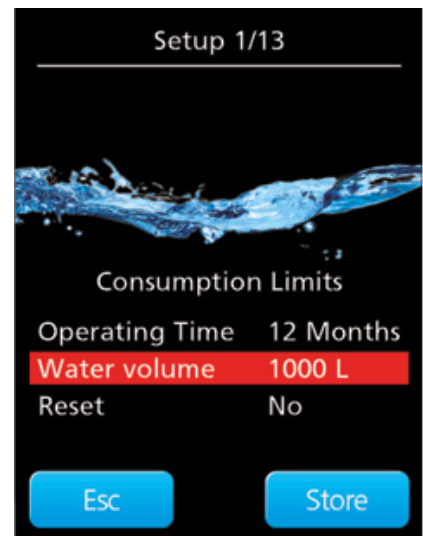
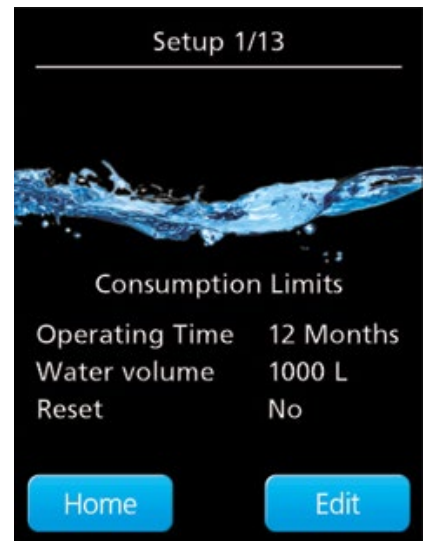

## 11.4 Volume metered water to be withdrawn

The withdrawal mode is activated by pressing the drop button, recognisable by a drop indicator under the withdrawal tap on the display. In the withdrawal display you have the option to select one of the preset withdrawal values. You can select one of the default values (see table below) using the arrow keys and confirm with the drop key. By pressing the drop button again, you start the withdrawal process, which is automatically stopped when the set withdrawal value is reached. However, you can stop the water dispensing at any time by pressing the drop button again. You can see the amount of water currently being withdrawn on the display while the water is being withdrawn. The conductivity of the ultrapure water is displayed to check the water quality.

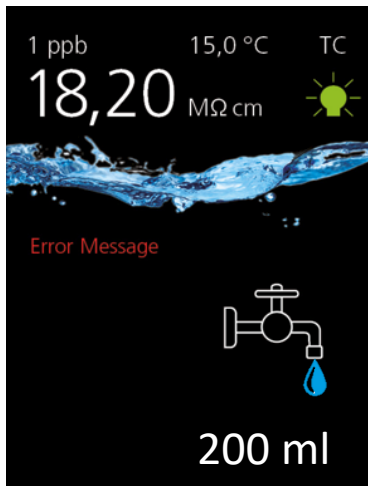

Preselectable withdrawal quantity in ml								
50	100	150	200	250	300	400	500	600
800	1000	2000	3000	5000	10000	20000	25000	

## 11.5 Client menu

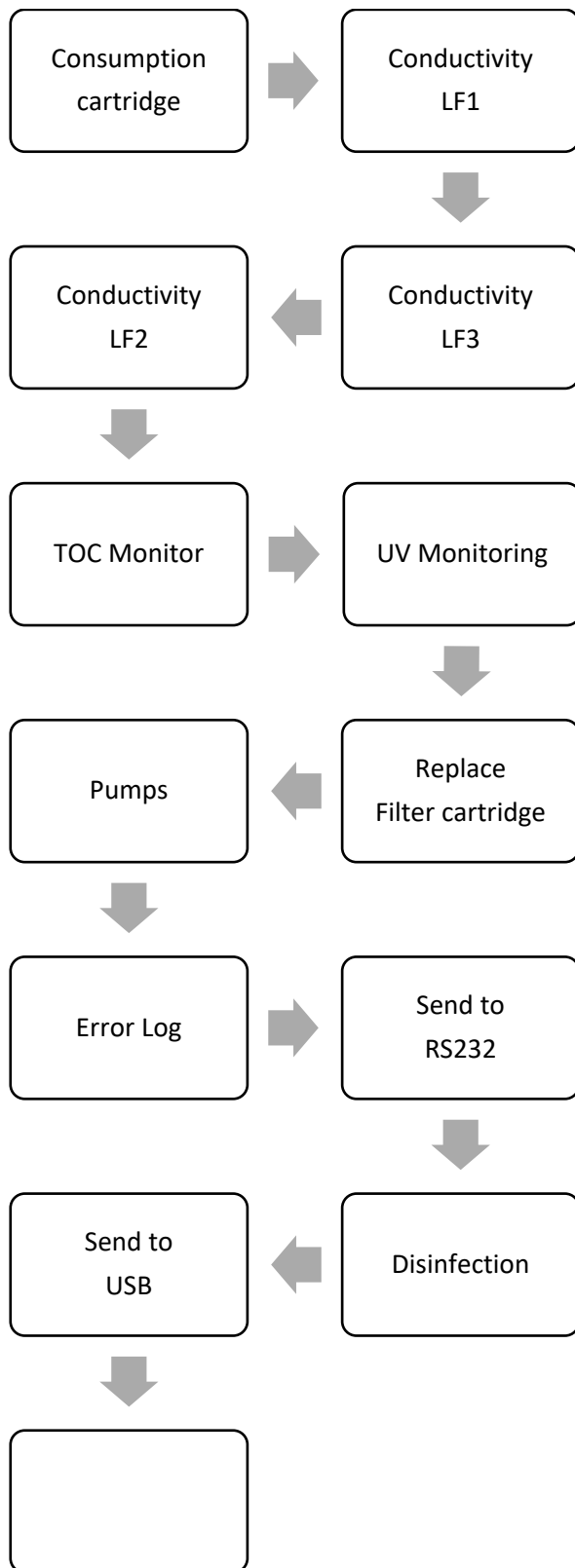

## 11.6 Setup menu

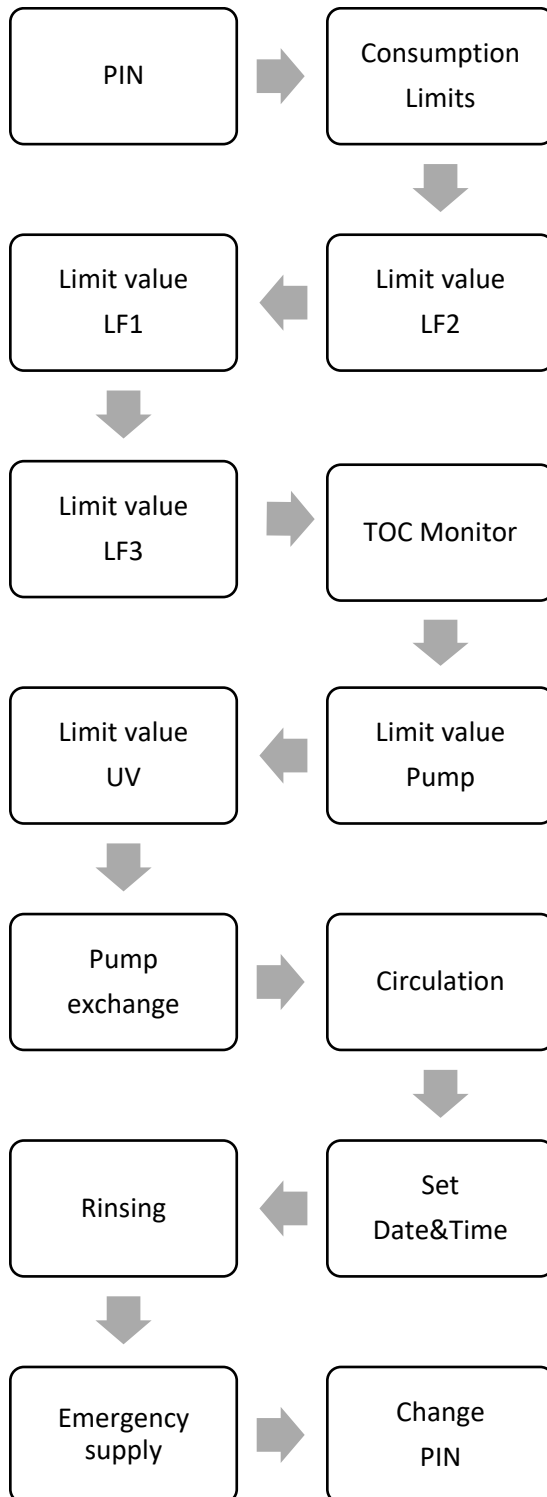

## 11.7 Calibrating menu

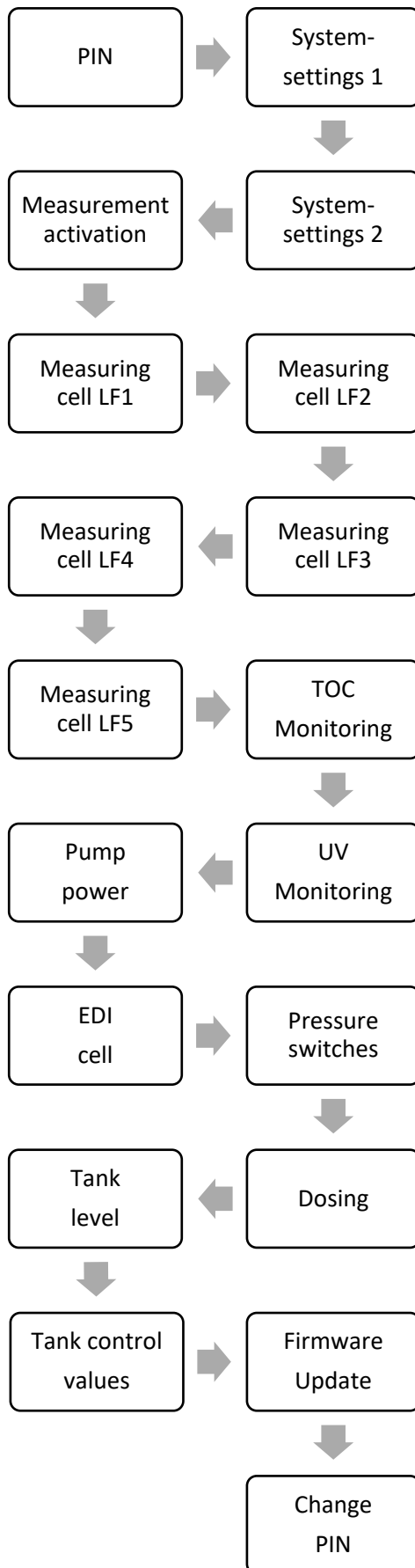

## 12 Commissioning

As soon as the power supply to the OmniaPure xs system is established, the system starts and the system name, serial number and software version are displayed for 3 seconds. The display then changes to the main display.

Start



Main display

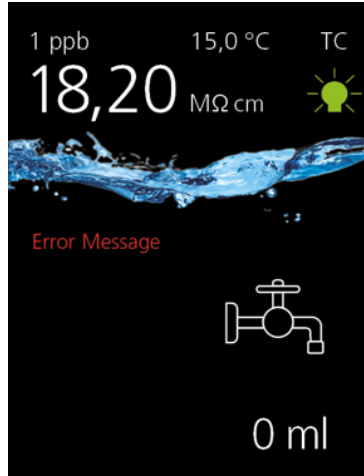

Now remove at least 2 litres of water by pressing the withdrawal button and discard the withdrawn water.

The system is now ready for use. It is automatically in recirculation mode. At the beginning, the conductivity can still be a little higher, but this improves in the course of the recirculation operation.

## 13 Maintenance

Regular maintenance and care of the OmniaPure xs system is required to ensure consistently good water quality. For professional and regular maintenance of the OmniaPure xs system, we recommend concluding a maintenance contract with an authorised customer service.



If improper maintenance, care and repair work is carried out on the system, the warranty for this system will expire. Likewise, the use of non-approved consumables and spare parts as well as any conversion measures will void the warranty and the CE declaration of conformity will no longer be valid.



**CAUTION**

Wear suitable protective clothing such as safety shoes, gloves or safety goggles to avoid injuries.



**CAUTION**

Water can escape through leaks. Therefore, always make sure that the floor in the area of the work surface is dry to avoid accidents caused by slipping.



**WARNING**

During assembly or maintenance work, the system must be disconnected from the power supply by pulling the mains plug, otherwise there is a risk of electric shock.

### 13.1 Maintenance / Care intervals

The frequency of maintenance measures essentially depends on the quality of the feed water and the amount of water drawn off. The maintenance intervals listed in the table below are recommendations and may be necessary earlier depending on the requirements of the ultrapure water.

Care measure	Article no.	Interval
Changing the pretreatment cartridge	19200102	12 months
Changing the ultrapure water cartridge	19200103	12 months*
Changing of the UV lamp	19100200	24 months
Changing the ultrafiltration module	19000050	24 months
Changing the sterile filter capsule	19100300	12 months
Disinfectant		12 months
Disinfection kit	19200091	
Disinfection agent	19200057	

\* In the customer menu, you can set the limit value for the water quantity after the first change of the filter cartridge. This allows you to adjust the change interval individually to your feed water conditions. The filter cartridge should then be changed after the limit value has been reached, but after 12 months at the latest.

## 13.2 Changing the cartridges

The cartridges have to be changed at regular intervals (12 months) or if the limit value you have specified is exceeded for a long time. The start of the interval is the point in time at which the respective filter cartridge was first connected to the system. Proceed as follows to replace the pretreatment and ultrapure water cartridge:

1. Turn off the OmniaPure xs system by disconnecting it from the mains voltage.
2. Swivel the Optifill dispenser with dispenser arm to the left or right to the side.
3. Remove the cover from the system. To do this, press the two snap locks on the side (see system description) and pull the cover hood forwards off the main housing.
4. The ultrapure water cartridge is on the left parking space, the pre-treatment cartridge is on the right parking space (see chapter assembly). Open the quick-release fasteners by pressing the clip (see figure) on the system's quick-release fastener and remove the cartridge to be changed.
5. Place the new cartridge in the appropriate slot in the system. Use the positioning aid on the bottom of the housing for easier positioning.
6. Connect the cartridge to the system using the quick-release fasteners. Make sure that the quick-release fasteners engage audibly.
7. Enter the code printed on the filter cartridge in the customer menu under the item "Change filter set" and confirm your entry.
8. Replace the cover and turn the OptiFill dispenser back to the desired position.
9. Plug the power cord back in to start the system.

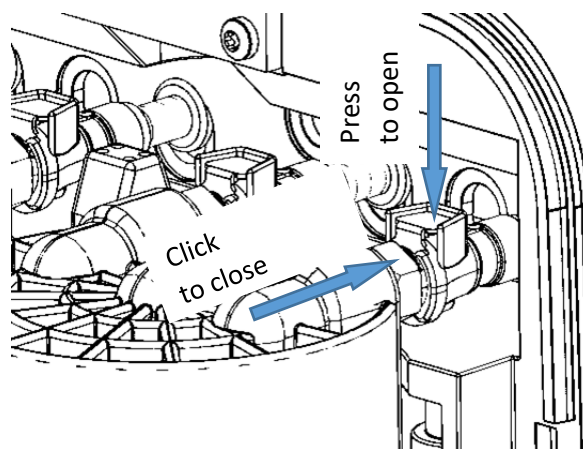



## 13.3 Disinfection

To protect the OmniaPure xs system from contamination from biological deposits, disinfection should be carried out at regular intervals (12 months). For the implementation you need the disinfection kit article no.: 19200091.



### **Risk of chemical burns!**

The disinfection of the OmniaPure xs system may only be carried out by appropriately qualified specialist personnel.

Protect yourself from injury by using appropriate safety clothing (at least gloves and goggles).

It is essential that you observe the safety data sheet enclosed with the disinfectant and follow the instructions for handling the disinfectant exactly.

Only use the disinfectant approved for the OmniaPure xs system.

The procedure for disinfection is described below. The duration of the disinfection process is about 30 minutes.

Open the "Disinfection" menu in the customer menu and confirm the start of the disinfection process. You will now be prompted to insert the disinfection cartridge into the device. To proceed, first prepare the disinfection cartridge with the disinfectant according to the instructions included with the disinfection kit. Then remove the ultrapure water cartridge from the system as described in the "Changing the cartridges" chapter. Insert the disinfection cartridge in the ultrapure water cartridge location and connect it with the quick-release fasteners. Confirm the insertion of the disinfection cartridge by pressing the Enter key.

If you want to cancel the process, you can do so within 10 seconds of starting by pressing the Stop button.

In the next step, the system starts circulating the disinfectant solution. After the end of the circulation phase, the system is flushed automatically. The remaining time is shown on the display, the entire process takes 30 minutes. This process cannot be cancelled and must be completed.

After the disinfection is complete, you will be prompted to reinsert an ultrapure water cartridge. To replace the cartridges, proceed as described in the "Changing the cartridges" chapter and end the process by pressing the Enter key. The system switches to normal operation.

# 14 Decommissioning & Dismantling

Decommissioning and dismantling may only be carried out by authorised specialist personnel.

If the OmniaPure xs system is to be decommissioned and dismantled, proceed as follows:

- Disconnect the system from the power supply by pulling out the mains plug
- Disconnect all hoses from the system connectors.

The system is now ready for dismantling.



Water can escape through leaks. Therefore, always make sure that the floor in the area of the work surface is dry to avoid accidents caused by slipping.

## 15 Spare parts

R+I Nr.	Designation	Art. no.
F4	Cap filter	31000041
FI1	Flow meter	25000070
LF1	Conductivity cell pretreatment	14180004
LF2	Conductivity cell ultrapure water	14180004
LF3	Conductivity cell TOC	14180004
LSZ1	Leakage sensor	50002819
P1	Circulation pump	29006000
UV	UV immersion tube UV ballast	19100201 26000060
V1	Inlet solenoid valve	50003160
V2	Circulation solenoid valve	50003160
V3	Pressure reducer	25200052
V4	Withdrawal solenoid valve	40000118
V5	Non-return valve	25200050
	Table power supply 48V 120W	26100016
	Circuit board interfaces	26000053
	Circuit board CPU TFT	50003163
	Replacement touch display incl. front handle	26000075

## 16 Consumables

R+I Nr.	Designation	Art. no.
F1	Pretreatment cartridge	19200102
F2	Ultrapure water cartridge	19200103
F3	Sterile filter capsule 0.2 µm	19100300
UF	Ultrafiltration module	19000050
UV	UV lamp 185nm, 11W	19100200

## 17 Accessories

Designation	Art. no.
Bio final filter 0.1 µm, negatively charged	19102100
Disinfection kit Omnia XS	19200091
Disinfection syringe including disinfectant (set of 3)	19200057
Wall holder Omnia XS	19200305

# 18 Faults / Messages

## 18.1 Faults table

<b>Fault</b>	<b>Possible cause</b>	<b>Remedy</b>
System does not start / Display does not function	No or faulty power supply	Ensure the power supply according to the specifications under "Technical Data".
No water can be withdrawn	System is not receiving water	Check the hose connection of the feed water supply. Open the domestic feed water supply.
	Inlet pressure is too low	Check the inlet pressure (feed water pressure) and increase it if necessary.
	Leakage sensor has responded	If the leak sensor comes into contact with water, the system inlet valve is closed to prevent further water leakage. Eliminate the leak and reset the error by rebooting the system.
	Inlet solenoid valve is defective	Please contact customer service
	Withdrawal solenoid valve is defective	Please contact customer service
The system does not flush The system does not flush	The purge solenoid valve is defective.	Please contact customer service
Withdrawal rate is too low	Inlet pressure is too low	Check the inlet pressure and increase it if necessary.
	Ultrafiltration module is blocked	The ultrafiltration module needs to be replaced
	The set system pressure is too low	The system's internal pressure regulator needs to be readjusted.

## 18.2 Error messages

Error messages are flashing and shown in red on the display. If there are several errors, they are displayed one after the other. After the error has been rectified, the display goes out after approx. 15 seconds.

Error messages	Possible cause	Remedy
Feed water limit	Pre-treatment cartridge is exhausted	Install a new pre-treatment cartridge
	Feed water does not meet the requirements	Check the quality of the feed water
	Limit for LF1 set too low	Check the setting for limit for LF1
Ultrapure water limit	Ultrapure water cartridge is exhausted	Replace the ultrapure water cartridge
	Pre-treatment cartridge is exhausted	Install a new pre-treatment cartridge
	Feed water does not meet the requirements	Check the quality of the feed water
	Limit for LF2 set too low	Check the setting for limit for LF2
Temperature feed water	Limit for LF1 is set too low	Check the temperature limit setting
	Feed water temperature too high	Check the feed water temperature
Temperature of ultrapure water	Limit for LF2 is set too low	Check the temperature limit setting
	Ultrapure water temperature too high	Check the feed water temperature
TOC cell temperature	Limit for LF3 is set too low	Check the temperature limit setting
	Feed water temperature too high	Check the feed water temperature
Operating hours UV	Max. operating hours of the UV lamp have been exceeded	UV lamp needs to be replaced
TOC limit	Limit for TOC is set too low	Check the TOC limit setting
	Feed water does not meet the requirements	Check the quality of the feed water
Uptime filter	The limit for the operating time of the ultrapure water cartridge has been reached	Insert a new filter cartridge
Measuring cell LF1	Defect of the Conductivity measurement LF1	Please contact customer service
Measuring cell LF2	Defect of the Conductivity measurement LF2	Please contact customer service

Measuring cell LF3	Defect of the Conductivity measurement LF3	Please contact customer service
Temp. sensor LF1	Defect of the Conductivity measurement LF1	Please contact customer service
Temp. sensor LF2	Defect of the Conductivity measurement LF2	Please contact customer service
Temp. sensor LF3	Defect of the Conductivity measurement LF3	Please contact customer service
UV lamp	UV lamp or UV ballast defective	UV lamp or UV ballast needs to be replaced. Please contact customer service
Leakage	Leaking hose connection or component in the device	Stop/disconnect the feed water supply to the system, de-energize the system by unplugging the power cord and contact service
Feed water pressure	No feed water supply, or feed water pressure is too low	Check the feed water supply, increase the feed water pressure if necessary

## 19 Disposal

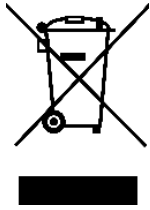

Stakpure ultrapure water systems are marked with a "crossed out trash can". This means that according to the European Regulation 2012/19/EU, your old electronic device may not be disposed of with normal household waste. You can hand in your old electrical equipment to one of the local recycling collection points for old electrical and electronic equipment, or Stakpure will dispose of your old equipment in a professional, environmentally friendly manner. To clarify the procedure for returning your old electronic device, please contact your retailer or contact us directly:

stakpure GmbH  
Frau Yvonne Reuter  
56414 Niederahr  
Phone: +49 2602 10673-107  
E-Mail: [yvonne.reuther@stakpure.com](mailto:yvonne.reuther@stakpure.com)

We expressly point out that according to § 19a ElektroG you have to delete any personal data on the devices to be disposed of.

In countries outside the European Economic Area, please contact the local authorities or disposal companies for disposal.

If the packaging of the device is no longer required, it can be disposed of with household waste.

## 20 EU declaration of conformity

### EU-declaration of conformity



in terms of directive(s):

- 2014/35/EU low voltage directive
- 2014/30/EU electromagnetic compatibility
- 2011/65/EU RoHS2 directive
  - incl. Commission Delegated Directive 2015/863

stakpure GmbH

Auf dem Kesseling 11

D-56414 Niederahr

Phone: 02602 10673-0 Fax: 02602 10673-200

info@stakpure.com www.stakpure.de

We hereby declare that the conception and form of the machine named below that we have brought to market are in accordance the determinations of the named article of the EU directive. This declaration is no longer valid when changes are made to the product.

Product:

Product designation: High purity water system  
 Type: OmniaPure xs<sup>touch</sup> UV-TOC  
 OmniaPure xs<sup>touch</sup> UV-TOC/UF  
 Art.No.: 18100004, 18100005

Standards applied:

DIN EN 55011:2022-05, DIN EN 61000-1-2:2017-07, DIN EN 61010-1:2020-03,  
 DIN EN 60204-1:2019-06, DIN EN IEC 63000:2019-05, DIN EN ISO 12100:2011-03

Niederahr, 01.06.2022

Jörg Groß, executive Director

Location, Date

authorized representative of the manufacturer



Signature









# stakpure

**stakpure GmbH**

Auf dem Kesseling 11

D – 56414 Niederahr

Ph.: +49 2602 10673-0

Fax: +49 2602 10673-200

[info@stakpure.com](mailto:info@stakpure.com)

[www.stakpure.de](http://www.stakpure.de)